

Operational Manual

EDU2AE - EDU2AE/HP- EDU2AE/HP_{RO}

Torque range: 0.2-50 Nm



IDENTIFICATION DATA OF THE MANUFACTURER

KOLVER S.r.l.
VIA M. CORNER, 19/21
36016 THIENE (VI) ITALIA

IDENTIFICATION DATA OF THE PRODUCT

MODEL:	EDU 2AE	EDU2AE/HP	EDU2AE/HP _{RO}
CODE:	031000	031000/HP	031000/HP _{RO}

TECHNICAL DATA OF THE PRODUCT

TRASFORMER: 230V or 100V AC 50 Hz – 40 V DC 200 VA FUSE: 3.15 A
DIMENSIONS: 195 x 170 x h110 mm WEIGHT: 3.7 Kg

DECLARATION OF CONFORMITY



KOLVER S.r.l. declares that the new tool here described: control unit model EDU 2AE is in conformity with the following standards and other normative documents: 2006/42/CE, 2006/95/CE, 2004/108/CE, EN 60745-1, EN 60204-1, EN 61000-6-1, EN 61000-6-3.

It is also in conformity with the RoHS II normative.

Name: Giovanni Colasante
Position: General Manager
Person authorized to compile the technical file in Kolver.

Thiene, Oct. 28 2013

Giovanni Colasante

EDU 2AE, EDU 2AE/HP and EDU 2AE/HP_{RO} power supply and control units are an innovative system for controlling the torque of any current control MITO and PLUTO electric screwdrivers: MITO15, PLUTO 3, PLUTO 6, PLUTO 10, PLUTO 15, PLUTO 20, PLUTO 35 and PLUTO50, either inline, pistol, for automation and with angle head (only PLUTO). It's also possible to use the following clutch models: PLUTO 3FR, PLUTO 5FR and PLUTO 7FR.

EDU 2AE, EDU 2AE/HP and EDU 2AE/HP_{RO} deliver all the advantages of precision torque control electric tools at a fraction of the price of transduced tools.

The state-of-the-art electronic control circuit cuts the power supply to the motor calculating the correct torque in response to 3 parameters; voltage, frequency and current, according to the selected options.

Model	Torque (Nm)		Speed	
	SOFT	HARD	Min	Max
MITO15	0,2-1,5	-	450	850
PLUTO 3	0,3-2	0,3-3	370	1200
PLUTO 6	0,5-6	0,5-8	200	920
PLUTO 10	2-8	1,5-10	110	600
PLUTO 15	2-15	2-15	60	320
PLUTO 20	2-18	2-20	40	210
PLUTO 35	2-35	2-35	40	140
PLUTO 50	5-50	5-50	20	90
With angle head (PLUTO ANG)				
PLUTO 6 ANG	0,5-6	0,5-6	200	920
PLUTO 8 ANG	1-6,5	1-8	110	600
PLUTO 15 ANG	2-13	2-13	100	320
PLUTO 20 ANG	2-17	2-19	60	210
With clutch (PLUTO FR)				
PLUTO 3FR	0,5-3,2	-	800	1300
PLUTO 5FR	0,7-5	-	600	1000
PLUTO 7FR	1,5-7	-	350	600

IMPORTANT: EDU 2AE, EDU 2AE/HP and EDU 2AE/HP_{RO} are highly accurate units but it is critically important to select the correct options to ensure that proper torque is being applied. Read the menu description carefully and in case of doubt please contact Kolver for support information.

Turn the unit on through the on/off switch on the back panel. The unit will carry a general system check and "waiting connection" will appear on the last line of the display. If the connection with the motor control board is successful the following screen will be displayed:

			K	o	l	v	e	r	S	.	r	.	l	.			
			E	D	U		2	A	E		H	P					
			V	e	r	s	i	o	n		1	.	3	0			
							l	o	a	d	i	n	g	.	.	.	

Press any key on the front panel to enter the main screen (see following picture).

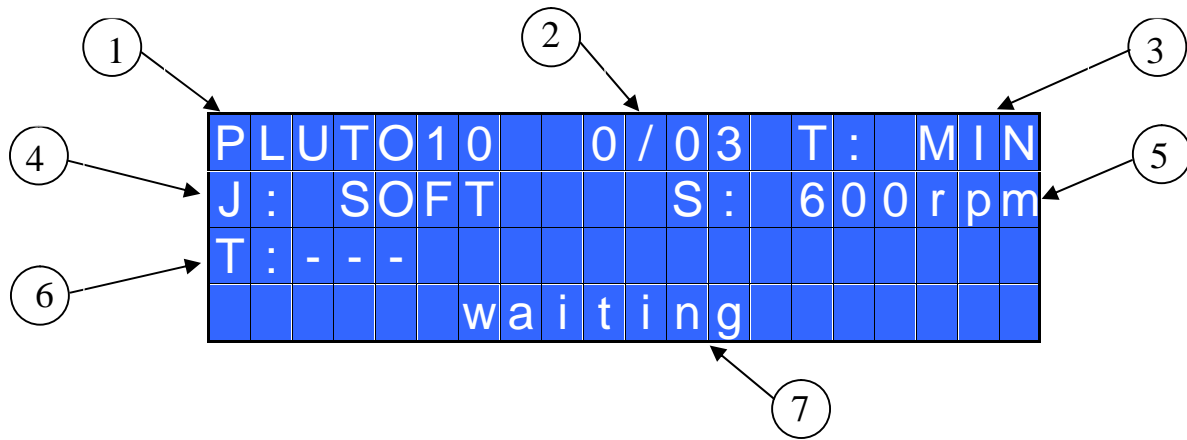

- 1- Screwdriver model
- 2- Screw count: fastened screws/total screws (model EDU 2AE/HP and EDU 2AE/HP_{RO} only)
- 3- Pre-set torque level (percentage)
- 4- Selected type of joint (Hard or Soft)
- 5- Selected speed
- 6- Reached torque level (model EDU 2AE/HP and EDU 2AE/HP_{RO} only) in Nm, in.lbs or kgf.cm.
- 7- Status bar (waiting, screwing, errors, etc...)



To enter the menu press **ESC** for 2 seconds.

Select the line by pressing \uparrow or \downarrow then press **OK** (the symbol \rightarrow will turn into \blacksquare). Press \uparrow or \downarrow to select the required value and then confirm through **OK** (or **ESC** if you don't want to save the value).

The selected value will be immediately operational, even if you are still in the menu screen. Repeat these operations for all the parameters you wish to set and then push **ESC** to return to the main screen.

FRONT PANEL LED:



GREEN LED: *Screw OK.*

YELLOW LED: *Program End or Sequence End (only on EDU 2AE/HP and EDU 2AE/HPro).*

RED LED: error.

MENU

The first 13 menu lines are available in the EDU 2AE, EDU 2AE/HP and EDU 2AE/HP_{RO}. Lines from 14 to 25 are only available in the HP and HP_{RO} models.

-	-	-	-	-	-	-	-	M	E	N	U	-	-	-	-	-	-			
O	K		c	h	a	n	g	e				E	S	C		q	u	i	t	
▶	1)	M	o	d	e	l	:				P	L	U	T	O	1	0		
	2)	T	o	r	q	u	e	:									M	I	N

1) Model: you can select the screwdriver to be used. Your choice will automatically change the default settings. It's important to select the correct model you're going to use since many parameters regarding the motor software are specific for every single model.

ATTENTION: The pre-set torque level in % and in Nm for PLUTO3FR, PLUTO5FR o PLUTO7FR models doesn't appear on the display. Moreover, some settings will be unchangeable, so if you try to modify such settings the following line will be displayed: "*not available for clutch*".

2) Torque: you can select the desired torque as a percentage of the torque range of the selected screwdriver. For example, for a Pluto10, a 50% setting on hard joint will result in a torque in the area of 4.5 Nm. The torque range is always referred to the MAX speed. In case you're not working at maximum speed, the torque range will progressively lower in order to avoid motor stalling. If the torque level is reached correctly, it will be showed on the display and you will hear a beep sound, too. Such torque level is indicated as "T: ..% " on the main screen.

-	-	-	-	-	-	-	-	M	E	N	U	-	-	-	-	-	-		
	3)	J	o	i	n	t	:								S	O	F	T
▶	4)	B	r	a	k	e		t	i	m	e	:				o	f	f
	5)	R	a	m	p		t	i	m	e	:				0	.	2	s

3) Joint: You can select the type of joint you are working on. A soft joint is typically a self tapping screw on plastic or sheet metal, or a metric (machine) screw on a material subject to strain (for example: gasket, o ring etc.) A hard joint is typically a fastener joining metal with metal. If you select the option SOFT the screwdriver will run at the selected speed (see point 6.). When selecting the option HARD the screwdriver will maintain the selected speed for a selected time after the start (see point 4.) and then the speed will be reduced automatically to apply a pre-torque before reaching the preset torque. The type of joint is indicated as "J" on the main screen.

IMPORTANT: An incorrect selection of the joint type can result in inaccurate torque output.

4) Brake time: This option can be selected only in combination with the option JOINT: HARD. It indicates how long the selected speed (higher speed) will be on before switching to "pre-torque speed" (lower speed). The "pre-torque speed" will be automatically chosen by the unit depending on the preset torque. You can set the brake time from 0.3 to 10.0 sec. To disable the function select OFF by pressing ⏴ as many times as needed. In this case the screwdriver will automatically start at pre-torque speed, which cannot be set by the user.

CAUTION: The aim of the BRAKE TIME is only to speed up the approach time in case of long screws. Reaching the torque at higher speed will result in inaccurate torque output. To avoid inaccurate torque values we suggest selecting a shorter time, and then increase it step by step until finding the optimum time. Torque reached during the Brake Time won't activate the torque signal and the message "*Error brake time*" will be displayed on the main screen together with 2 beep sounds. The red led will turn on, too.

5) Ramp: You can select the slow start time (acceleration) from 0.2 to 3.0 sec. This option is only available for the screwing phase, while during the unscrewing phase the ramp time is always 0.2 sec. We suggest using this option with self tapping screws.

ATTENTION: Reaching the torque while the ramp is still on could give as result a different torque level from the one that results when the ramp is over. This is due to the motor acceleration.

Reaching the torque while the ramp is still on will activate the “screw OK” signal anyway (this option is useful if you need to tighten screws that are already tightened, the so called “double hit”).

On the other hand, if you wish to see an error signal during the preset torque in the ramp phase, you can change the minimum time by setting value which is equal or superior to the ramp value (see point 7).

-	-	-	-	-	-	-	-	-	M	E	N	U	-	-	-	-	-	-	-		
6)	S	p	e	e	d	:						6	0	0	r	p	m			
→	7)	R	u	n	T	i	m	e	:								o	f	f	
8)	M	i	n	T	i	m	e	:										o	f	f

6) Speed: You can select any speed value of the screwdriver between the maximum and the minimum specific speed of every single screwdriver (see table with technical data).

7) Run time: You can set the time of a tightening, from OFF to 20.0 sec. When the pre-set time has been reached, it results in a torque signal.

The couple reached during this time results in a signal of *Correct screw*. If the correct screw signal is not required, set the Minimum time up to a value of 'Minimum Time -0.1sec'.

ATTENTION: Max Time must be set at 20.0 sec.

8) Minimum Time: You can set this time from 0.1 sec to 'Max time - 0.1s'. To disable the function select OFF by pressing ↵ as many times as needed. (Min time = 0).

Torque reached below the minimum time won't activate the torque signal and will result in an error signal. “*Below minimum time*” will be displayed on the status bar and the red led will light up. You will hear two beep sounds, too.

-	-	-	-	-	-	-	-	-	M	E	N	U	-	-	-	-	-	-	-
9)	M	a	x	T	i	m	e	:				2	0	.	0	S		
→	10)	A	u	t	o	r	e	v	:						1	.	0	s
11)	R	e	v	s	p	e	e	d	:	6	0	0	r	p	m			

9) Maximum time: You can select the maximum time of tightening. You can set from 'Min time + 0.1s' to 20.0 sec.

ATTENTION: If torque isn't reached by the maximum time, the screwdriver will stop. “*Over maximum time*” will be displayed on the status bar and the red led will light up. You will hear two beep sounds, too.

10) Auto Rev: This option will automatically start a reverse after a torque reached/ correct screw signal. You can set time from 0.1 to 20.0 sec.

To disable the function select OFF by pressing ↵ as many times as needed.

ATTENTION: During the reverse, it is necessary to keep the lever or the start signal pressed as long as it won't stop. “*Correct screw*” will be displayed on the status bar and a green led will light up. You will hear one beep sound, too. In case the lever is released before the end of the reverse, “*unfinished screw*” will be displayed and a red led will light up. You will hear two beep sounds, too.

11) Rev speed – Reverse speed: You can select any reverse speed value of the screwdriver between the maximum and the minimum specific speed of every single screwdriver (see table with technical data).

-	-	-	-	-	-	-	-	M	E	N	U	-	-	-	-	-	-			
1	2)	R	e	v			t	o	r	q	u	e	:			M	A	X	
▶	1	3)	L	a	n	g	u	a	g	e	:						E	N	
1	4)	P	r	e	-	r	e	v	.	:							o	f	f

12) Rev torque – Unscrewing torque: You can select the desired torque as a percentage of the torque range of the selected screwdriver (see point 2). If the torque is set on MAX, the unscrewing torque is about 20% higher than the possible maximum torque, so that it is always possible to unscrew the tightened screw (we suggest leaving this function on in normal use). If the setting is from MIN to 99% the unscrewing torque with the same percentage will be equal to the settings of the screwing phase.

ATTENTION: If you're using open-end wrenches, the unscrewing torque has to be set to MIN value in order to bring the wrench back to the correct position.

13) Language: This option allows to select among 4 languages: English, Italian, German and Spanish.

The following menu is available in the HP and HP_{RO} models only

14) Pre-Rev. - Pre-reverse: You can set a reverse before a screwing.

Time can set from OFF to 20.0 sec.

ATTENTION: Pre-reverse speed and torque are the same as Auto Rev.

-	-	-	-	-	-	-	-	M	E	N	U	-	-	-	-	-	-		
1	5)	P	V				T	o	r	q	u	e	:			o	f	f
▶	1	6)	R	o	t	a	t	i	o	n	:			r	i	g	h	t
1	7)	C	h	a	n	g	e		p	a	s	s	w	o	r	d		

15) PV torque: Period of time in which the screwdriver works at maximum torque before switching to the torque that has been set by the user. You can set time from 0.1 to 10.0 sec. To disable the function select OFF by pressing ↵ as many times as needed.

This function overlaps other time settings (brake time, ramp time, minimum time, maximum time) from the motor start on.

ATTENTION: This function is useful for applications where the prevailing torque is higher than the final torque (for example trilobal screws or locknuts).

Please use this function with utmost attention because an incorrect use can damage both the assembly and the screwdriver.

Torques reached during the max torque time won't activate the torque signal. "Error tm max torque" will be displayed and the red led will light up. You will hear two beep sounds, too.

16) Rotation: You can choose between right tightening (standard screws) or left tightening (left threaded screws). All the other functions will adapt to the selected direction of rotation.

17) Change password: You can change password (see point 16).

-	-	-	-	-	-	-	-	M	E	N	U	-	-	-	-	-	-	
1	8)	P	a	s	s	w	o	r	d	:					o	f	f
▶	1	9)	C	a	l	i	b	r	a	t	i	o	n			O	N
2	0)	C	o	m	p	e	n	s	:	+	0	.	0	0	N	m	

18) Password: If YES, you will be asked for the password to enter the menu. Otherwise select NO.
ATTENTION: Password is only asked to enter the menu for the first time after switching the unit on.
 The default password is: 0000.

19) Calibration: ON allows to see the torque value on the main screen. OFF doesn't show the torque value.

(To modify the calibration parameters see paragraph *Torque calibration*).

20) Compens – Compensation: This function allows an increase or decrease of the displayed torque after calibration. The available range is from 0 to ±9.99 Nm. For example: after calibration (see Torque calibration) you make a screwing on your assembly and compare the value you see on the main screen display with the value you see on a torque tester (for example a mini-K or a K model). Let's say you notice that the torque displayed in the unit EDU 2AE/HP is +0.2 Nm higher than the value indicated on the tester (which is the right one). In this case you change this value by setting -0.2 Nm so that the value on the screen will be the same as the value on the tester. If it's lower than 0.3 Nm, you need to set +0.3 Nm and so on.

-	-	-	-	-	-	-	-	M	E	N	U	-	-	-	-	-	-	
2	1)	U	n	i	t	:									N	m	
▶	2	2)	T	o	r	q		m	i	n	:	0	.	0	0	N	m
2	3)	T	o	r	q		m	a	x	:	4	0	.	0	0	N	m

21) Unit: You can choose between the following units of measurements: Nm, in.lbs and kgf.cm.

22) Torq min – Minimum torque: The minimum torque and maximum torque options allow the user to set the acceptable torque range for each single application. When the reached torque is inside this range, “tightening OK” will be displayed on the status bar and the green led will light up. If the reached torque is outside this range the messages “error minimum torque” or “error maximum torque” will be displayed. You can set the torque range from 0 to 40 Nm at intervals of 0.01 Nm.

The minimum torque option allows to set the lowest value of the torque range and it's on if calibration is 'ON'. If calibration is 'OFF' the minimum torque value automatically sets on 0 Nm.

23) Torq Max – Maximum Torque: The minimum torque and maximum torque options allow the user to set the acceptable torque range for the single application. When the reached torque is inside this range, “right screwing” will be displayed on the status bar and the green led will light up. The messages “below minimum torque” or “over maximum torque” will be displayed if the reached torque is outside this range. You can set the torque range from 0 to 40 Nm at intervals of 0.01 Nm.

The maximum torque option allows to set the highest value of the torque range and it's on if the calibration is 'ON'. If the calibration is 'OFF' the maximum torque value automatically sets on 40 Nm.

-	-	-	-	-	-	-	-	M	E	N	U	-	-	-	-	-	-
2	4)	S	c	r	e	w	s		n	u	m	b	e	:		3
▶	2	5)	O	K	/	E	S	C	:						N	O
2	6)	C	y	c	l	e	s	:	0	0	0	0	0	0	0	0

24) Screws number: The EDU2AE/HP and the EDU 2AE/HP_{RO} can act as screw counter. You can set the number of screws from 1 to 99. To disable the function select OFF by pressing ↵ as many times as needed.

If the number of correct screws is equal to the number of set screws “Program end” will appear on the status bar and the yellow led will light up. If the OK/ESC function is disabled (see point 23), “Program end” will automatically disappear at next screwing or when you enter the menu. Otherwise, press OK at the end of each program.

ATTENTION: Every time you enter the menu, the number of screws resets to zero.

25) OK/ESC: If YES, press OK at the end of a cycle of screwings or ESC if an error message is displayed. If NO, every notification automatically resets at next screwing.

26) Cycles - Number of total screwing/errors done which have been carried out (**if you have an EDU2AE control unit, you’ll find this function on line 14**): It shows the number of fastened screws and occurred errors. This number can’t be modified.

TORQUE CALIBRATION

It is necessary to have a torque tester to proceed with the torque calibration operation.

Please read the instructions carefully.

The torque calibration function allows to view the torque value in Nm or in.lbs directly on the display.

ATTENTION: The displayed torque level is approximate and it’s determined by mathematical calculations. The smaller the calibration interval the more precise the value on the screen.

IMPORTANT WARNINGS:

- Calibration values will be referred to the parameters of the control unit which are set during calibration. If you modify speed or type of joint the unit will need to be recalibrated.
- If the screwing during calibration isn’t carried out correctly or if you’re not sure of the value it’s possible to repeat it. A wrong screwing can affect the precision of the calibration.
- Calibration is carried out at two torque levels optionally chosen. The minimum calibration interval is 5% (example: if I have to work at 30%, I can calibrate at 25% and 35%) but we recommend a minimum of 10% interval.
- Torque percentages which are higher than the maximum one set during the calibration will be analyzed and displayed anyway. They will be theorized by the system and they won’t be based on effective data, therefore the analysis won’t be precise.
- During the calibration it’s impossible to go back to the previous screen. Press ESC to stop calibration and then repeat it.

CALIBRATION PROCESS:

1. Select Calibration at point 17 of the menu and press OK.
2. The following screen will appear on the display:



3. Choose if you want to set calibration ON or OFF, then press OK to confirm or ESC to exit. If you choose OFF, calibration will be interrupted and no torque value will be displayed. If you choose ON, calibration will continue and the following screen will be displayed:

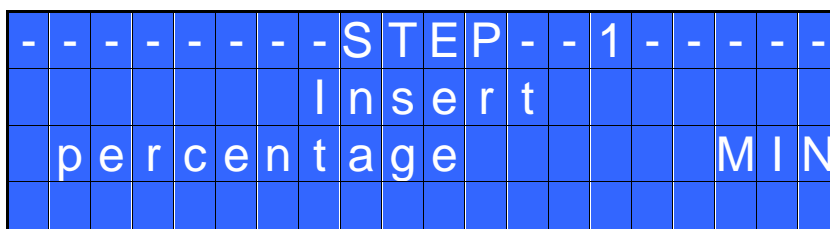

4. Set the first torque level percentage by pressing \uparrow or \downarrow , then press OK.
5. Complete a fastening cycle.
6. If you're sure of the torque level displayed on your torque tester press OK, then set the displayed value and press OK again to save. Otherwise press ESC and start again.
7. The following screen will be displayed. Set the percentage of the second torque by pressing \uparrow or \downarrow and press OK.

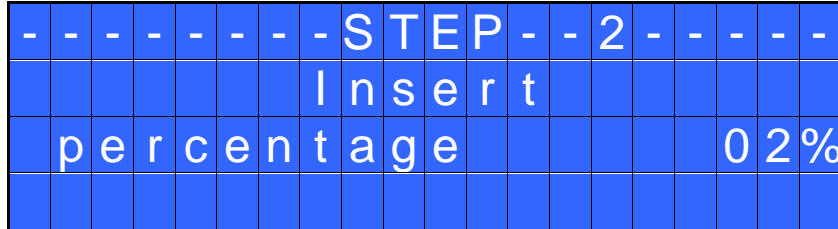

8. Repeat the procedures described on points 4, 5 and 6.
9. When calibration ends, “*Setting end*” will be displayed. You will hear two beep sounds, too.

ATTENTION: If you press ESC after confirming “calibration ON”, the display will show the torque screen again and the displayed values are the default ones or the ones set during the previous calibration (if done before).

INTERPRETATION OF ACOUSTIC SIGNALS

The control unit emits sounds which help you understand if the screwing has been carried out correctly or not. When the torque is reached meeting all the parameters set, the control unit utters a 0.5 sec beep as confirmation. In case of Program End, the unit will utter other two beeps. On the other hand, torque reached under min time, during the Ramp time or under the Brake time (see error signals on the display) will cause the control unit to utter three beep sounds.

I/O CONNECTIOS



- CN1 CONNECTOR – 10 pin:
On the back panel, in all the EDU 2AE units, there is a 10 pin I/O connector.

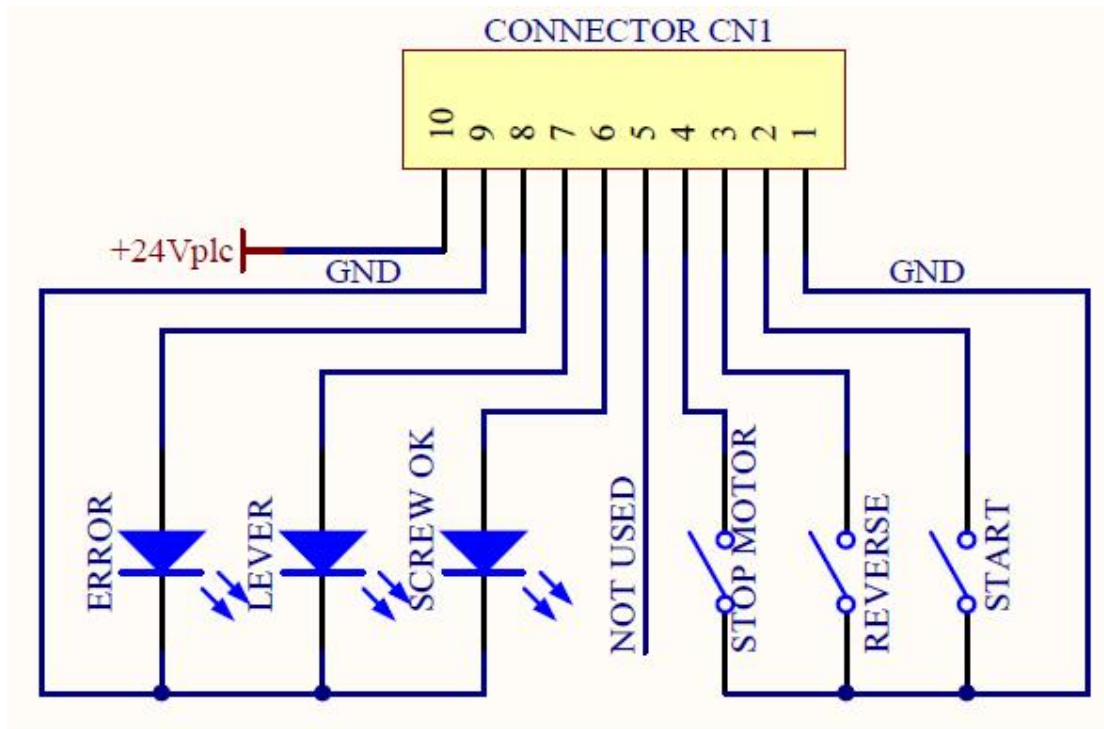

INPUT:

PIN	NAME	FUNCTION
1	GND	Common pin. By closing the contact between pin 1 and any of the other pins (2, 3, 4, 5) to start the function you need. This pin is connected to 0VDC and to the ground.
2	START	Remote start. Clockwise. Torque control.
3	REVERSE	Reverse remote start. Counterclockwise. Torque control.
4	STOP	Stop motor. "STOP MOTOR ON" screen. Motor stops and starts again after the contact has opened.
5	NOT USED	Only used in special versions.

OUTPUT:

PIN	NAME	FUNCTION
6	SCREW OK	Torque reached/ Screw OK signal. It activates whenever the tool performs a correct screwing, that is when all the settings have been fulfilled. Signal is 24VDC.
7	LEVER	Lever signal: when lever is pressed or when the start is remote. No signal during a reverse. It resets after their release. Signal is 24VDC.
8	ERROR	Error signal: it activates every time an error occurs. Error signal resets when the torque is reached or after releasing the lever or of the remote start. Signal is 24VDC.
9	GND	Common pin for any output. Signals must be taken between this pin (0VDC common) and the other pins (6,7 and 8).
10	+24Vplc	+24V tension to see the ouput signals. Max 400mA. DO NOT USE IT FOR EXTERNAL DEVICES.

- CN2 CONNECTOR – 8 pin:
Only on EDU 2AE/HP_{RO}

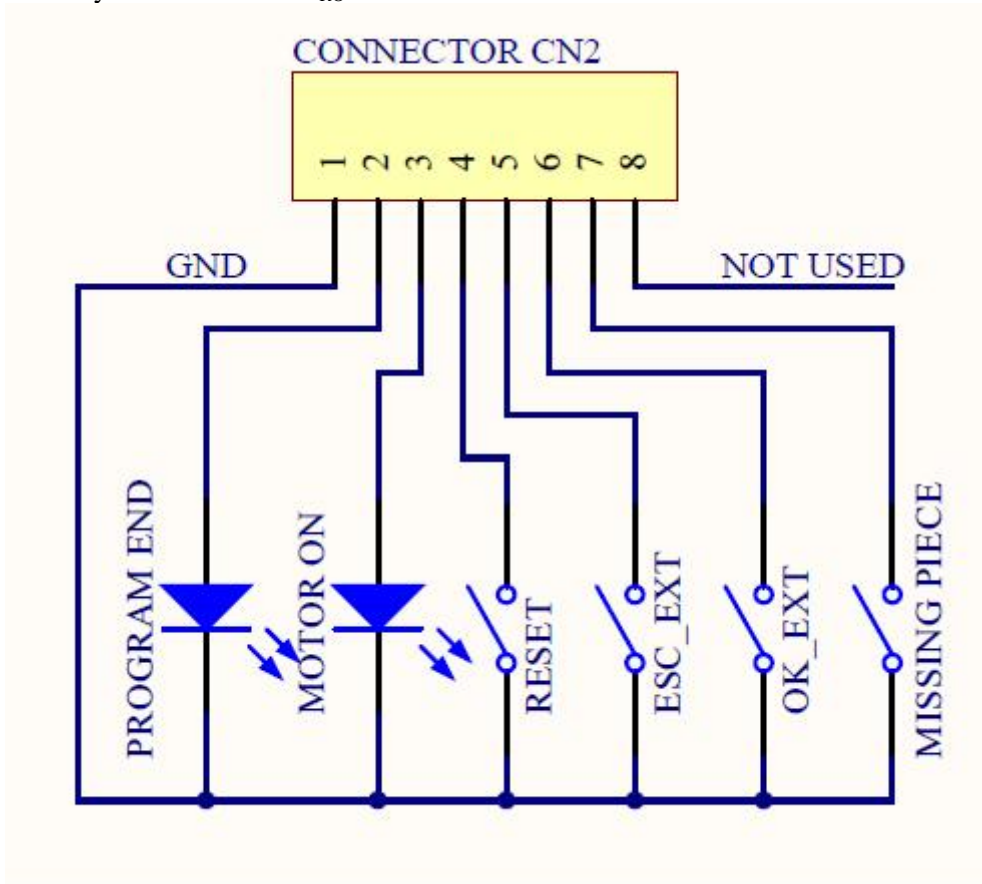

PIN	NAME	FUNCTION
OUTPUT		
1	GND	Common pin for any input and output. By closing the contact between pin 1 and any of the other pins (2, 3, 4, 5, 6, 7) to start the function you need. This pin is connected to 0VDC and to the ground.
2	PROGRAM END	It activates at the end of each program.
3	MOTOR ON	It activates when the motor runs while tightening.
INPUT		
4	RESET	If pressed for at least 1 sec, it resets the program you are working in.
5	ESC_EXT	If enabled, (see point 9: OK/ESC), remote ESC key function to reset errors.
6	OK_EXT	If enabled, (see point 9: OK/ESC), remote OK key function to confirm program end.
7	MISSING PIECE	If enabled, it stops the motor, it enables the error signal and "Error missing piece" is displayed on the status bar.
8		Not used.

ATTENTION: Output signals are protected from an appropriate circuit. Overload of the available signals (> 450 mA) or short circuit will result in the stop of the unit. To re-activate signals, it is necessary to switch off the unit for 5-6 seconds, check connections and output loads then switch the unit on.

- CN3 CONNECTOR (9 pin serial connector – male)

Only on EDU 2AE/HP_{RO}

PIN	NAME	FUNCTION
1	+15 Vcc	Not used.
2	TX	Serial transmission.
5	COM 0VDC	Common pin for any input. Signals must be taken between this pin (0VDC common) and the other pins of this connector depending on the signal you want to be printed.

TROUBLE SHOOTING

ERROR	PROBLEM	SOLUTION	
0	“ <i>waiting connection</i> ” doesn’t turn into “ <i>system ready</i> ” after it’s been switched on.	Contact your nearest Kolver dealer.	
1	“ <i>tightened screw</i> ” is displayed on the status bar (the torque signal is displayed during the motor startup process which lasted 0.3 sec).	<p style="text-align: center;">For HP and HP_{RO} models: If the ON/OFF function is on press ESC for a new screw; if it’s disabled it automatically resets next time you screw.</p> <p style="text-align: center;">For 2AE model: The error automatically resets next time you screw.</p>	
2	“ <i>Error brake time</i> ” is displayed on the status bar (the torque signal is displayed during the brake time).		
3	“ <i>Rev. incomplete</i> ” is displayed on the status bar (the displayed torque signal is correct but the set unscrewing is not complete).		
4	“ <i>Pre-reverse incompl.</i> ” is displayed on the status bar (the lever has been released before the Pre-Rev. has been completed).		
5	“ <i>Below min time</i> ” is displayed on the status bar (the torque signal is displayed below the set minimum time).		
6	“ <i>Over maximum time</i> ” is displayed on the status bar (the torque signal is displayed over the set maximum time).		
7	“ <i>Error PV torque</i> ” is displayed on the status bar (the torque signal is displayed inside the set maximum time).		
8	“ <i>Below min torque</i> ” is displayed on the status bar (the torque signal is displayed below the set minimum time).		
9	“ <i>Over max torque</i> ” is displayed on the status bar (the torque signal is displayed over the set maximum time).		
10	“ <i>Compensation error</i> ” is displayed on the status bar (the torque value is negative – this is due to an excessively high negative compensation value)		- Set a higher/lower compensation value.
11	“Error unscrew torque” is displayed on the status bar (The torque signal is displayed while unscrewing, but only if it’s set on “max”).		- The screwdriver couldn’t unscrew. - Avoid motor stalling. - Unscrewing too heavy.
12	“Protection 12A” is displayed on the status bar (it happens when current on mosfets of bridge H is > 12 A for at least 1 sec).		- Reduce cycle rate and check settings. - Avoid motor stalling. - Unscrewing too heavy. - Joint too soft.

13	“Protection 14p5A” is displayed on the status bar (it happens when current on mosfets of bridge H is > 14.5 A for at least 800 ms).	<ul style="list-style-type: none"> - Reduce cycle rate and check settings. - Avoid motor stalling. - Unscrewing too heavy. - Joint too soft.
14	“Protection 15A” is displayed on the status bar (it happens when current on mosfets of bridge H is > 15 A for at least 500 ms).	<ul style="list-style-type: none"> - Reduce cycle rate and check settings. - Avoid motor stalling. - Unscrewing too heavy.
15	“OUTPUT DISABLED” is displayed on the status bar. It is on the protection of the output signals exceeding the maximum load (400mA).	<ul style="list-style-type: none"> - Check that the load does not exceed the max (400mA) - To reset, restart the unit.

ATTENTION: IF THE OK/ESC OPTION IS DISABLED, ERRORS RESET AT THE FOLLOWING SCREWING/PROGRAM. OTHERWISE PRESS ESC. IF THE PROBLEM PERSISTS, PLEASE CONTACT YOUR NEAREST KOLVER DEALER.

CORRECT SCREWS ON STATUS BAR

“Screw OK” is displayed on the status bar.	The tool has performed a correct screwing, that is when all the settings have been fulfilled.
“Run Time OK” is displayed on the status bar.	The tool has performed a correct screwing, that is when all the settings have been fulfilled.
“Rev. Torque OK” is displayed on the status bar.	The tool has performed a correct screwing, that is when all the settings have been fulfilled.

SERIAL PORT only on EDU 2AE/HP_{RO}:

EDU 2AE/HP_{PRO} control unit is supplied with a serial 9 pin male connector. In this way you can print the results of each screwing. The transmission characteristics are the following:

9600 (bits per second), 8 (data bits), n (no parity), 1 (bits stop 1).

Connection pin: PIN 2 = TX, PIN 5 = GND

The print string is the following:

RESULT	SCREWDRIVER MODEL	% TORQUE	JOINT	SPEED	TORQUE	SCREW COUNT	NOTICE
--------	-------------------	----------	-------	-------	--------	-------------	--------

In case of error the string is as follows:

RESULT	SCREWDRIVER MODEL	% TORQUE	JOINT	SPEED	ERROR NOTICE
--------	-------------------	----------	-------	-------	--------------

Result = screw evaluation: correct or incorrect.

OK = the torque has been correctly reached, all the selected parameters are satisfied and the control unit will give out a beep sound of 0.5 sec.

NOK = the torque has been reached during the ramp time or the brake time (see error table). In this case, the unit will give out 2 beep sounds and the red led will light up.

Screwdriver model = model of selected screwdriver.

% Torque = percentage of the set torque level.

J: Joint = type of joint (H= hard or S=soft).

S: Speed = speed value.

T: Torque = torque value.

Screws: Count = number of screws screwed/number of total screws of the sequence/ program.

Notice = in case of program end, it prints "Program end".

In case of errors:

Error notice = type of error.

Example of serial print:

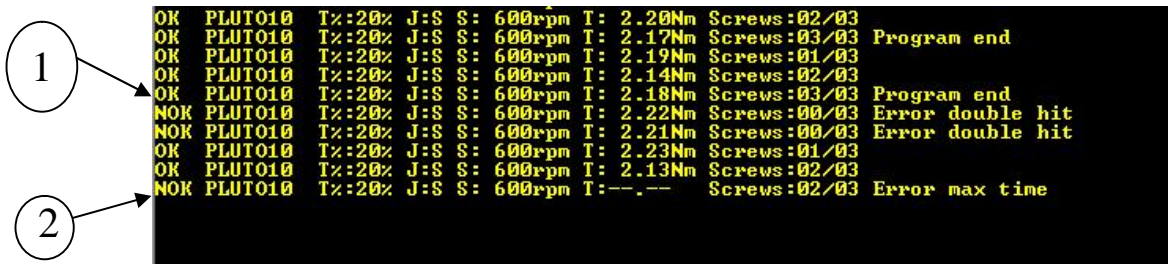

```
OK PLUTO10 T%:20% J:S S: 600rpm T: 2.20Nm Screws:02/03
OK PLUTO10 T%:20% J:S S: 600rpm T: 2.17Nm Screws:03/03 Program end
OK PLUTO10 T%:20% J:S S: 600rpm T: 2.19Nm Screws:01/03
OK PLUTO10 T%:20% J:S S: 600rpm T: 2.14Nm Screws:02/03
OK PLUTO10 T%:20% J:S S: 600rpm T: 2.18Nm Screws:03/03 Program end
NOK PLUTO10 T%:20% J:S S: 600rpm T: 2.22Nm Screws:00/03 Error double hit
NOK PLUTO10 T%:20% J:S S: 600rpm T: 2.21Nm Screws:00/03 Error double hit
OK PLUTO10 T%:20% J:S S: 600rpm T: 2.23Nm Screws:01/03
OK PLUTO10 T%:20% J:S S: 600rpm T: 2.13Nm Screws:02/03
NOK PLUTO10 T%:20% J:S S: 600rpm T:--.-- Screws:02/03 Error max time
```

1) example of screw OK

2) example of error

EXPLODED VIEW OF THE CONTROL UNIT

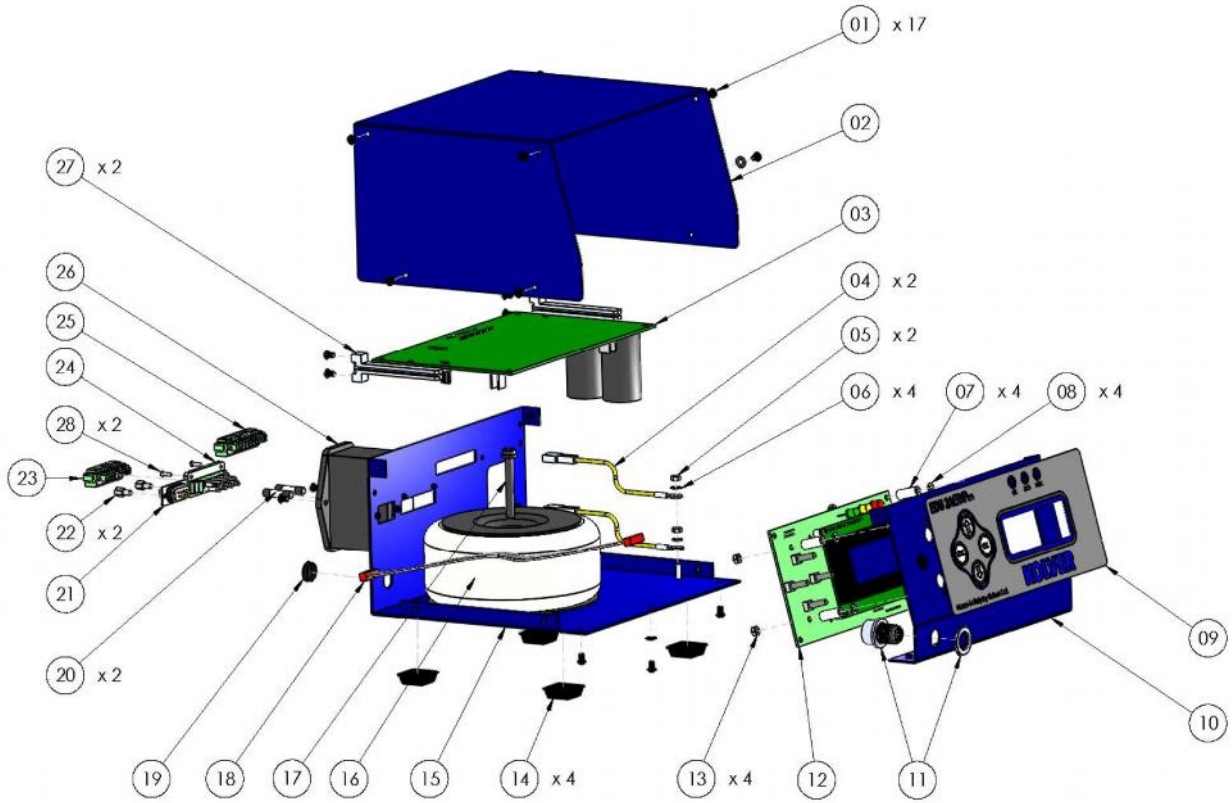

SPARE PARTS:

Position	Description	Code
1	Screw M3x5 (17)	872443
2	Upper panel 2AE	818003
3	Main PCB	852521
4	Ground cable (2)	800090/E
5	Brass nut M3 (2)	800056/O
6	Washer M3 (2)	800041
7	Spacer 15 mm (4)	890004
8	Flat washer M3 (4)	800042
9	Membrane	818004
	Membrane HP	818005
	Membrane HPro	818009
10	Front panel	818002
11	Connector M12 5 pin + nut	201666/R1
12	PCB display EDU2AE	852522
	PCB display EDU2AE/HP e HPro	852522/HP
13	Zn-white nut M3 (4)	800056
14	Plastic support (4)	800016/B
15	Bottom panel 2AE	818001
	Bottom panel 2AE/HP and HPro	818007
16	Transformer 230V 200VA	845009
	Transformer 110V 200VA	845009/110
17	Screw M6x40	872430/N
18	Flat	872438
19	Cover	800168
20	Fuse (2)	800619
21	Serial connector F	890005/F
22	Spacer M3 M-F	872453
23	Connector 8 pin F	872464
24	Connector 8 pin M	872457
25	Connector I/O 10 pin spacing 3,81	800102
26	Filtered plug	800718
27	Board plastic support	872442
28	Screw M2x6	801004

GUARANTEE

1. This KOLVER product is guaranteed against defective workmanship or materials, for a maximum period of 12 months following the date of purchase from KOLVER, provided that its usage is limited to single shift operation throughout that period. If the usage rate exceeds of single shift operation, the guarantee period shall be reduced on a prorata basis.
2. If, during the guarantee period, the product appears to be defective in workmanship or materials, it should be returned to KOLVER or its distributors, transport prepaied, together with a short description of the alleged defect. KOLVER shall, at its sole discretion, arrange to repair or replace free of charge such items.
3. This guarantee does not cover repair or replacement required as a consequence of products which have been abused, misused or modified, or which have been repaired using not original KOLVER spare parts or by not authorized service personnel.
4. KOLVER accepts no claim for labour or other expenditure made upon defective products.
5. Any direct, incidental or consequential damages whatsoever arising from any defect are expressly excluded.
6. This guarantee replaces all other guarantees, or conditions, expressed or implied, regarding the quality, the marketability or the fitness for any particular purpose.
7. No one, whether an agent, servant or employee of KOLVER, is authorized to add to or modify the terms of this limited guarantee in any way. However it's possible to extend the warranty with an extra cost. Further information at kolver@kolver.it.